

WEBB-STILES COMPANY

Manufacturers of Engineered Conveyor Systems

IMAGINEERING CONVEYOR SYSTEMS TO MEET YOUR NEEDS

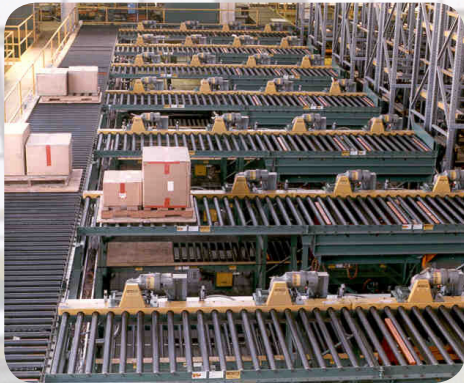

WEBB-STILES OVERHEAD CONVEYORS

Webb-Stiles Overhead Conveyor Systems are one of the most popular types of conveyor. Our systems are manufactured in 3", 4", and 6" standards and we are capable of designing more complex overhead systems; involving special custom engineered components for unusual applications.

Webb-Stiles Overhead Components are pre-engineered and based on industry standards; eliminating high costs of custom engineering and long delivery delays.

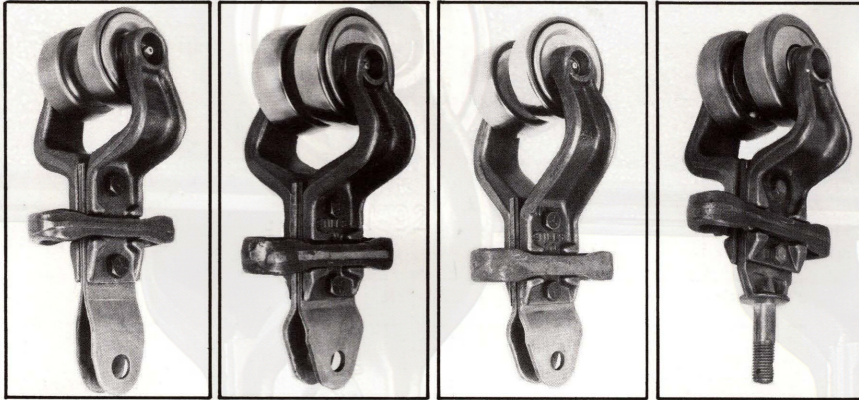

TROLLEY ATTACHMENTS

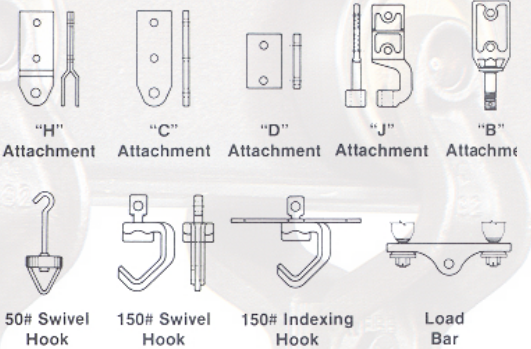

FULL LINE OF 3", 4" AND 6" TROLLEY, RAIL & ATTACHMENTS

We maintain stock on all the 3", 4" and 6" rail in 1045. Full ball open or sealed trolleys in 3", 4" and 6" sizes and a complete line-up of trolley attachments.

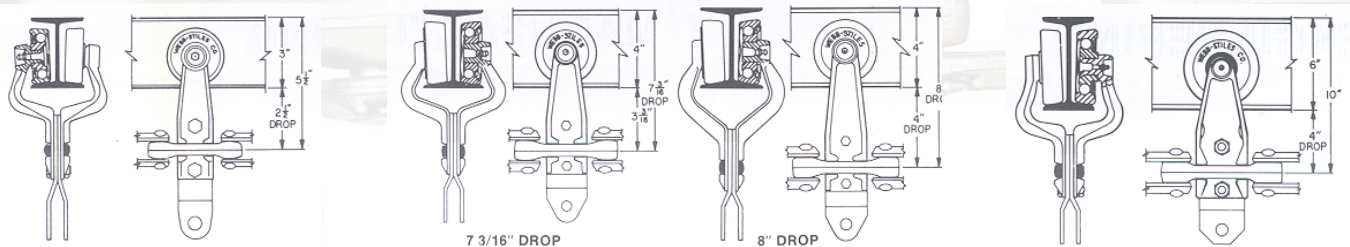

CHAIN

WEBB-STILES rivetless overhead conveyor chain is drop forged from high carbon steel and consists of three components; connecting pins, side links and center link. Individual links or sections can easily be replaced without tools. The chain is designed to flex for negotiation of horizontal and vertical curves.

Three sizes are used.

- X-348 - 3" pitch for 3" overhead trolley
- X-458 - 4" pitch for 4" overhead trolley
- X-678 - 6" pitch for 6" overhead trolley



TAKE-UPS

Take-ups are available in Traction Wheel or Roller Turn and provide for chain stretch. Available in all standard radius and diameter. They also come in spring, screw or air operated.

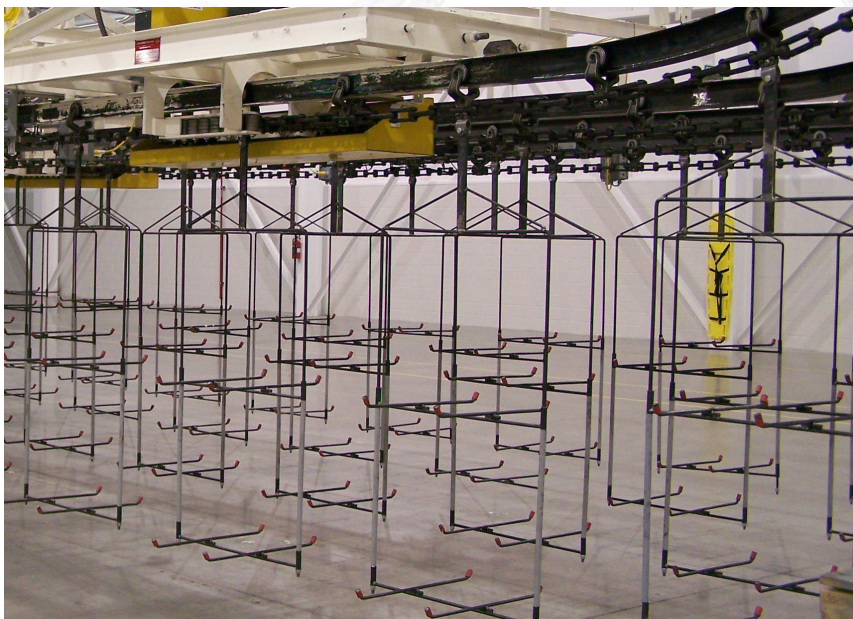

We also have these components for our Overhead Conveyor Systems:

- 3", 4", 6" Traction Wheel Turns
- 3", 4", 6" Roller Turn Rolls
- Traction Wheel or Roller Turn Take-Ups
- Vertical Bends
- Safety Stops
- Expansion Joints

See our Catalog for More Information.



GREAT REASONS TO CHOOSE WEBB-STILES CONVEYORS & COMPONENTS

1. WEBB-STILES offers a complete line of Trolley Conveyor Systems and components.
2. WEBB-STILES overhead trolley components are pre-engineered and based on industry standards, eliminating high costs and long delivery delays.
3. WEBB-STILES trolley systems can be expanded and modified by use of additional components and accessories.
4. WEBB-STILES manufacturing is geared for high volume production and cost savings.
5. WEBB-STILES has over 50 years of experience worldwide in manufacturing and installation ease behind every system and component.
6. WEBB-STILES maintains a large inventory of component parts, many available for immediate shipment.
7. WEBB-STILES can design complex trolley systems involving special custom engineered components and multi-drive systems.
8. WEBB-STILES can handle field installations for complete turn-key operation.
9. WEBB-STILES can automate systems with custom load or unload devices and other types of interface equipment.



DRIVE UNITS

Conveyor drives are the most important components of all conveyor systems. WEBB-STILES drives are simple, rugged, dependable and designed for maintenance free operation. Two standard conveyor drives are available:

Caterpillar and Sprocket.

Variable speed units with manual or electrical remote speed control are available.

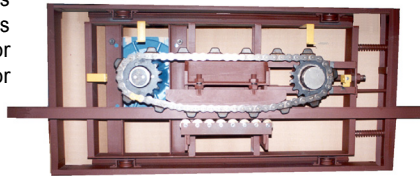

CATERPILLAR:

These drives are the most popular for Overhead Conveyors. They can be located in any straight run of track. This makes the proper drive and take-up relationship easier to achieve. Caterpillar drives are mandatory on systems having a heavy chain pull. Fixed or floating frame styles.

SPROCKET:

These drives are of limited application, in that they must be located on a 90° or 180° horizontal turn. Sprocket drives have a large diameter steel sprocket keyed to the drive reducer output shaft. Larger reducers with heavier shafts and bearings are usually required.

TRACTION WHEELS, ROLLER TURNS, VERTICAL BENDS

WEBB-STILES furnishes standard Traction Wheels in Box or T-Frame and Roller Turns in 30, 45, 60, 90 and 180 Degree Turns. Bearings are available as regreaseable, sealed for life or graphalloy. Custom size turns are available. Vertical bends are available in 30 and 45 degree in several standard radiuses. Special bends and compound vertical dips can also be furnished.

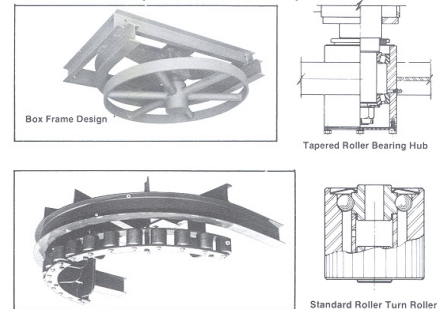

ENCLOSED TRACK POWER & FREE

WEBB-STILES ENCLOSED TRACK AND POWER & FREE

WEBB-STILES Power and Free Conveyors are now available in Enclosed Track for your lighter duty applications and where an enclosed track is an advantage. Our Power and Free systems give you all the advantages of accumulating, switching, stopping, banking and many other special features.

- Enclosed track is formed with high strength steel for long life and low maintenance.
- The enclosed track chain can withstand 400°F in continuous duty. Up to 450°F with intermittent duty.
- WEBB-STILES carriers are a single cast body with four heavy duty wheels and are available in Leading, Intermediate, and Trailing configurations.
- WEBB-STILES offers a Heavy Duty 3" Line Carrier utilizing 3" channel to accommodate 3" Power and Free Trolleys.

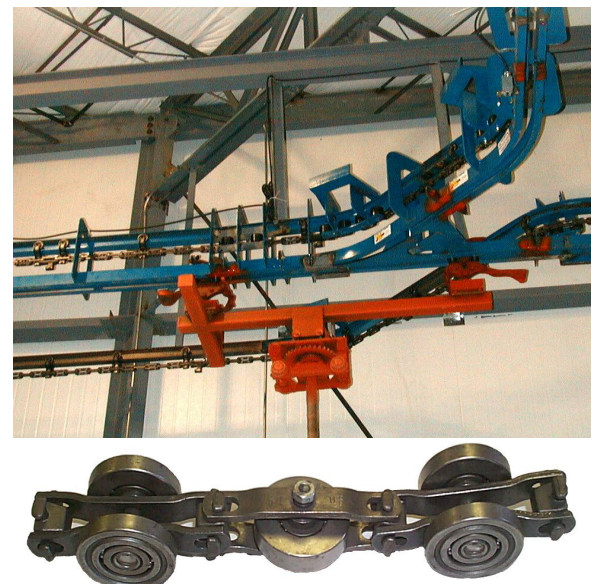
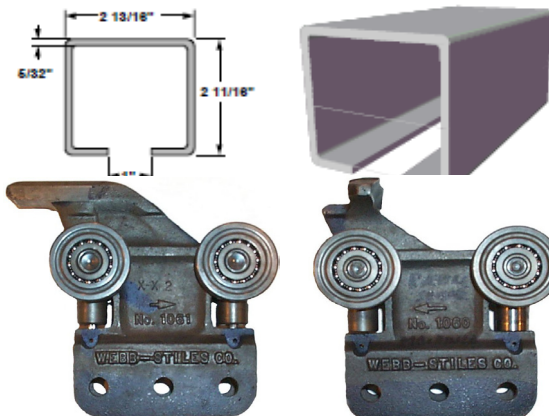

WEBB-STILES OVER & UNDER POWER & FREE

WEBB-STILES Over and Under systems consist of an "I" beam power track with standard WEBB-STILES power chain and trolleys above a "toe to toe" free channel track coupled together with "Yoke" supports. The free trolley runs inside the two channels.

The carrier trolley is engaged or disengaged from the power drive by a self-contained retracting dog mechanism. The dog can be activated by a cam arm in front or by manual or automatic stops.

Over & Under is well-suited to high density accumulating storage and systems requiring many switches in close proximity with spurs off both sides of the main line.

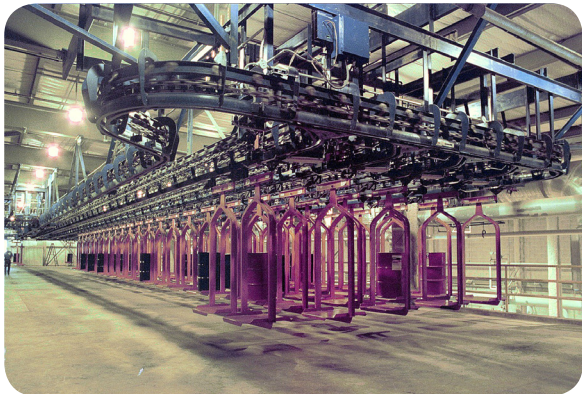
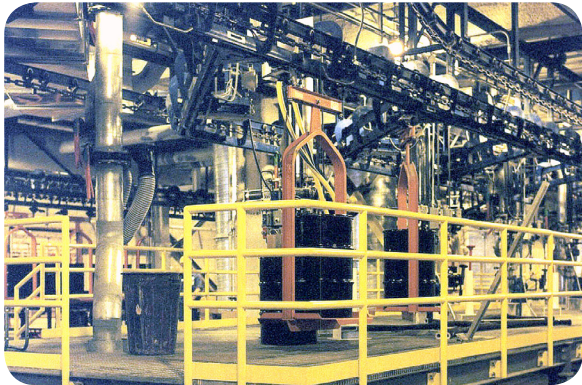

- Available in 3", 4" and 6" systems.
- Trolley wheels available in Full Ball Complement, open or closed wheel. Wheels are swaged on full length axles for high strength.
- Made from a single-piece casting, all bodies are then precision machined.
- Beaver tail has gradual incline for efficient stops and starts.
- A WEBB-STILES anti-rebound device locks a trolley wheel on the 4" Power & Free Trolley to keep from backing-up and rebounding.
- A trolley pusher dog with wear surfaces provide a gradual incline on dog that allows for smooth disengagement at mechanical stops.
- The hold-back dog features bulletproof simplicity.
- Center guide rollers feature pressure type grease fittings.
- Guide rollers are easily replaceable without removing trolley from the track.
- Accumulating paddles, one piece high strength casting provides a smooth positive actuation.

WEBB-STILES SIDE PUSH POWER & FREE

WEBB-STILES Side-Push systems feature an off-set double "I" beam arrangement. The upper power rail features a pusher trolley that engages the lower free rail carrier trolley from the side.

Standard high quality WEBB-STILES "off the shelf" chain and trolley monorail components make for a rugged low maintenance system. Side-Push is best suited to systems that require transportation, with a moderate number of switch locations and accumulation.

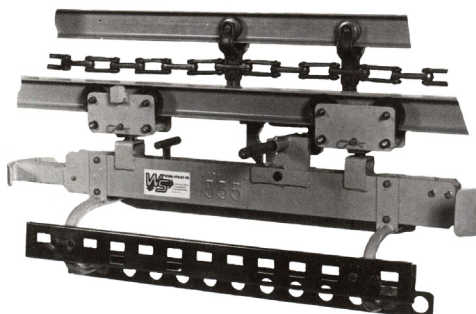



TYPICAL DRAG LINES

Drag lines are an over and under chain conveyor that is used to tow loads in a straight line. Drag lines are engineered to the length and load requirements of the tow line. An important part of the tow line is the tow carts or methods used in towing the loads. We can also design and manufacture these to your requirements.

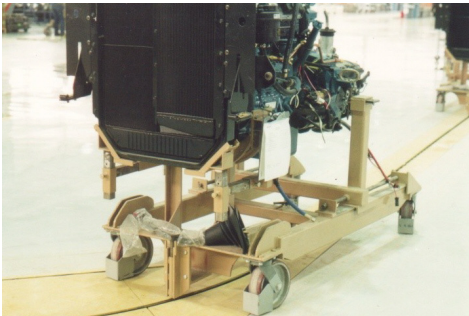
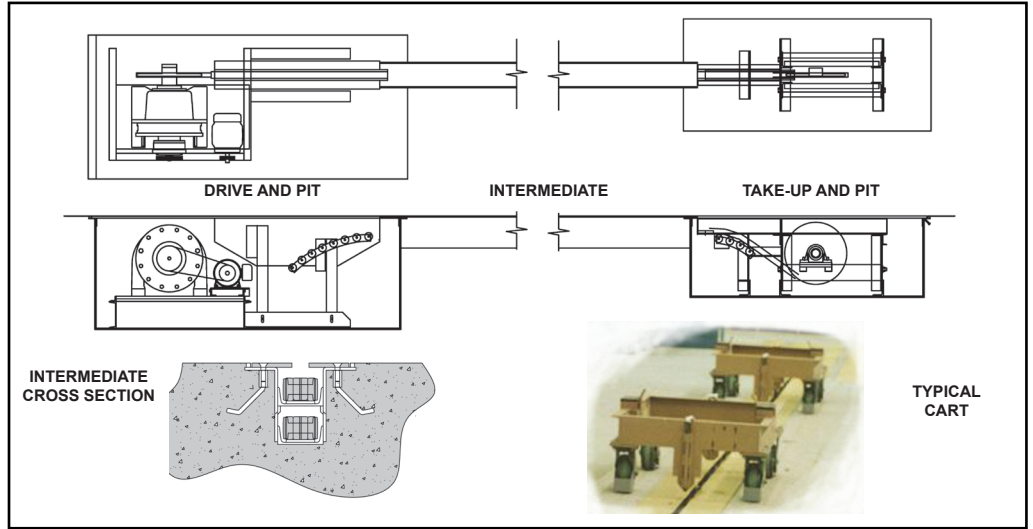

LOW SELECTOW AND DEEP CHANNEL

Low Selectow tow lines use a special 6" pitch chain that requires no take-up. Made in a closed loop configuration where carts are generally captive to the conveyor. These can be engineered with switches and spurs.

Deep channel tow lines use trolleys to support the chain and incorporate pusher dogs or fixed centers. Deep channel has the ability to make elevation changes.

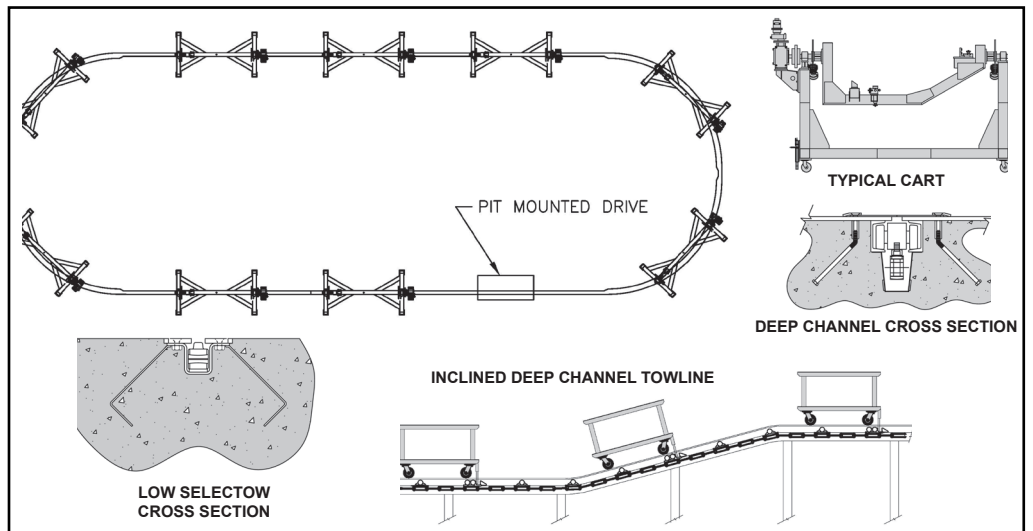

ON THE FLOOR AND CUSTOM

Flex tracker is our pre-engineered tow line that sits on the floor and can be easily moved. Used extensively in the wiring harness industry. Webb-Stiles also engineers above floor straight line pusher systems and custom engineered systems for special applications.

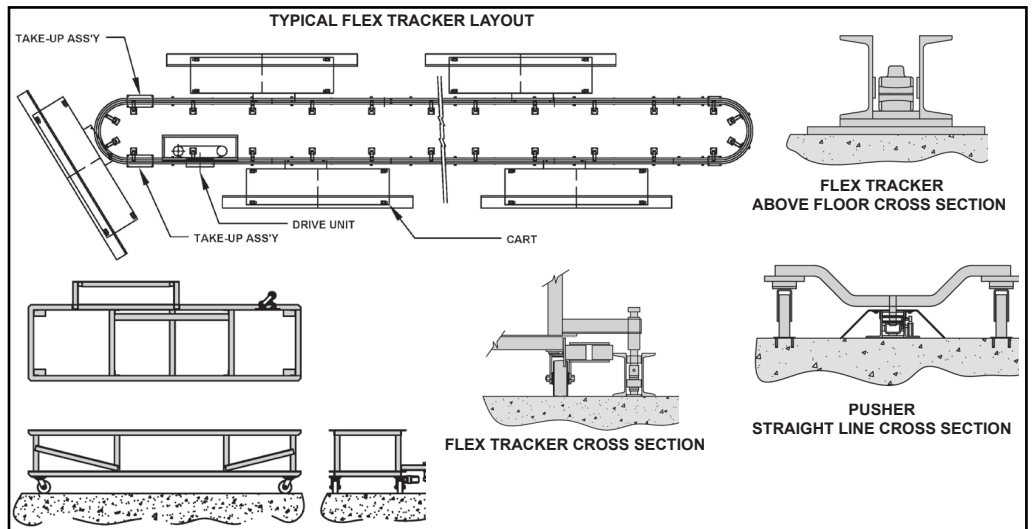

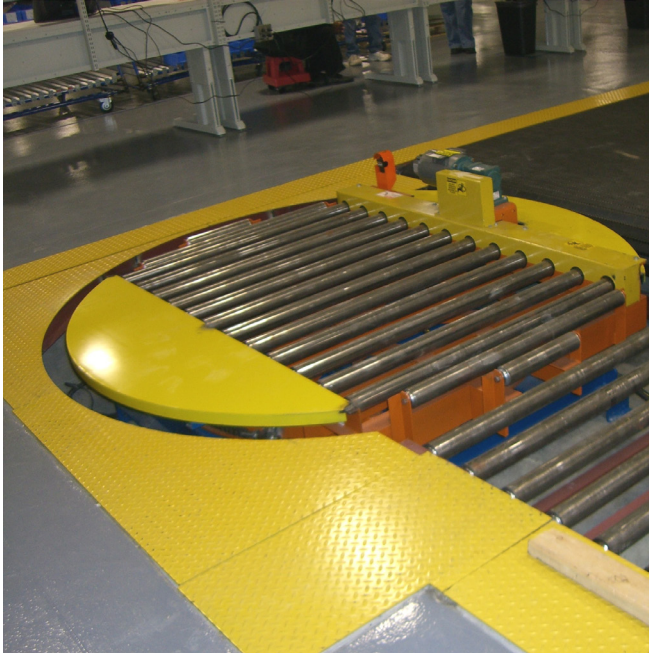

The Moving Floor Conveyor from Webb-Stiles is one of our newest innovative conveyors. We have done installations with very satisfied customers, for our newest type of conveyor, with great success.

This unique plastic replaces typical steel slat top chains and is capable of handling very heavy loads. The belting is available in several different surface textures including rubber top and available in any width required for the project.

The Moving Floor Conveyor has the versatility to be used in a wide range of applications; Assembly lines, including manrider belts, Material Handling, including pallet and other heavy-duty product applications, Wash Down, Meat, Bakery, and Packaging Lines.

In addition to being put in pits, this conveyor can also be floor supported with heavy duty supports or suspended overhead like a typical belt conveyor.

Give your Webb-Stiles Sales Engineer a call to learn more on this versatile conveyor.

- Can have high or low friction carrying surface.
- Uses smaller diameter sprockets for better conveyor to conveyor material transfers.
- Food Grade Rated.
- Modular design allows for easy maintenance and less down time.
- No lubrication required.
- Unique sprocket engagement allows long conveyors with reduced pulsation.
- Belts are self tracking and therefore require little to no maintenance.
- Can be used in a wide range of industries from automotive to food processing.
- Can be used in ovens, freezers, washers, and wash down duty applications.
- Modular design allows for a wide range of belt widths.
- Belts can be open or closed top depending on application.
- Very high load carrying capabilities.
- Tight bend radius.
- No take-up required therefore less maintenance intervention.
- Molded attachments can be added for special applications.
- Reduced Noise Level.
- Extremely wear and impact resistance.
- Rough top surface available, reducing slippage and allowing safe movements.

TRANSFER CARS

TRANSFER CARS

Transfer Cars are used in many material handling applications to move loads from different conveyor lines, for pack-out stations, die transfers and other handling operations. Extremely heavy loads can easily be moved and most types of materials.





- Components are pre-engineered and available from stock.
- System can easily be expanded and/or modified by use of additional components and parts.
- Carry a complete line of gravity roller conveyor assemblies, components and accessories.
- Most components in stock and ready to ship.
- Our facility offers the most automated production facility for fabrication and assembly of gravity rollers.
- All of our Conveyor rolls are manufactured at our facility.
- All rollers are available in any quantity in any length up to 96" BF for swaged rolls and 104" for reamed rolls.
- Our standard Ten Conveyor Roll Sizes have capacities from 75 to 4000 lbs in any size and quantity.
- Our "Hush-veyor" rolls not only allow you to comply with OSHA standards but they also offer a much more pleasant work environment.



Gravity roller conveyors are recommended for handling packaged commodities having a reasonably smooth, flat or firm bottom surface to contact the rolls. Irregular and flexible items can be conveyed if they are placed on pallets or in containers.

Gravity roller conveyors are the basis of most package handling installations because of simplicity, economy and negligible maintenance. WEBB-STILES roller conveyors are available in a wide range of types and sizes, to suit the individual job requirements.

The roller conveyors may be used for level line installations where the commodities are temporarily stored and manually pushed forward as required, or they may be sloped downward, causing the commodity to travel forward by gravity.



1 1/4" DIA. — 250# CAP.



1.9" DIA. x 16 GA — 260# CAP.



1.9" DIA. x 12 GA — 260# CAP.



1.9" DIA. x 9 GA — 250# CAP.



2 1/2" DIA. — 250# CAP.



2 1/2" DIA. — 580# CAP.

3350# with precision bearings



2 1/2" DIA. — 580# CAP.

3350# with precision bearings



3 1/2" DIA. — 580# CAP.



3 1/2" DIA. — 1090# CAP.

5850# with precision bearings

SUPPORTS

ADJUSTABLE TYPE PERMANENT SUPPORTS

Heavy duty roller conveyors are usually installed in a permanent position. For floor support at the desired height a series of adjustable, two-legged stands are available. Supports are of similar construction and in harmony with the conveyor frames.

TYPE "S" SUPPORTS

Formed channel uprights provide maximum strength in minimum size and are connected by jig welded cross ties. Standard "Type S" supports have a load rating of 1500 lbs per support, and are available in standard heights from 12" to 48" and for conveyor frames with "BETWEEN FRAMES" dimensions of 7" to 51".

All "TYPE S" support "HEIGHT" dimensions are based from floor to top of support.

HEAVY DUTY SUPPORTS

WEBB-STILES heavy duty supports are constructed of structural channel for maximum strength and load capacity. They are connected by jig welded cross braces. Heavy duty supports have a load rating of 3000 lbs per support, and are available in standard heights from 17" to 45" and conveyor frames with "BETWEEN FRAMES" dimensions of 7" to 51".

Check out our Catalog or our website www.webb-stiles.com, for more information.





CHAIN DRIVEN LIVE ROLLER (CDLR)

For positive load traction and heavy-duty or continuous conveyor operation, a WEBB-STILES roll-to-roll drive system is highly recommended. Each conveyor roll is positively linked by two separate loops of chain to each adjacent roll.

A full line of roll sizes and auxiliary equipment is available either pre-engineered or custom designed.

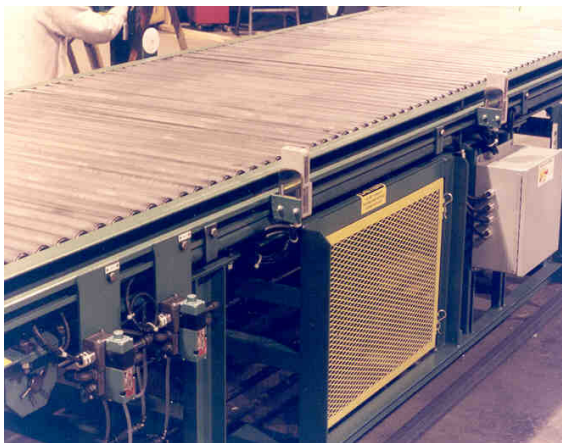
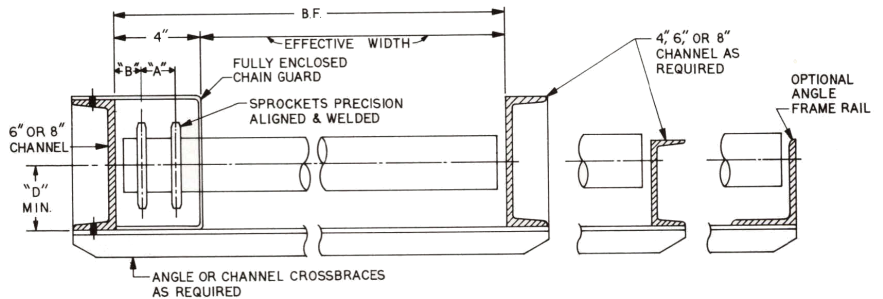

BELT DRIVEN LIVE ROLLER (BDLR)

WEBB-STILES Belt Driven Live Roller Conveyors (BDLR) offer economical solutions for many powered material handling systems. WEBB-STILES can build straightforward pre-engineered BDLR's and custom engineer highly sophisticated accumulating conveyors like our "ALPHA" system.

Belt Driven Live Roller conveyors work best in a relatively clean environment where dirt, abrasives and other contaminants will not attach to the drive belt.

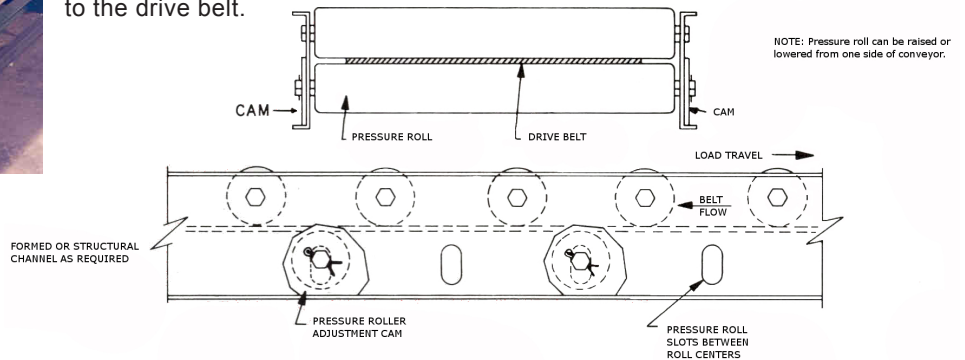

LINESHAFT DRIVEN LIVE ROLLER (LDLR)

WEBB-STILES Lineshaft Driven Live Roller Conveyors (LDLR) offer economy, quiet operation, cleanliness and safety. The system features a powered lineshaft, bearing mounted, that runs the length of the conveyor. Special pulleys are mounted on the lineshaft. A urethane belt connects the lineshaft pulley to the individual rollers. The rolls have grease packed bearings and a circumferential groove on one end. They are typically mounted on 3" centers, but can also be on 4" or 6" centers.

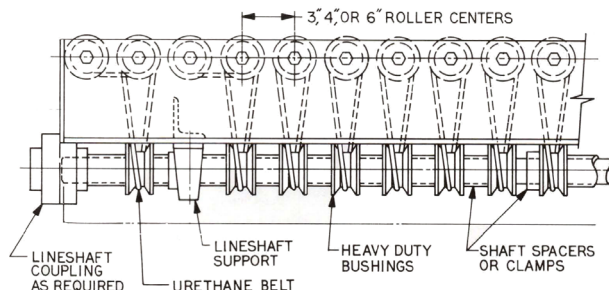



WEBB-STILES BELT CONVEYORS

Belt Conveyors fulfill diverse applications in material handling and manufacturing. Slider bed, roller bed, or combinations are available to meet most material and load handling requirements. WEBB-STILES offers a limitless variety of belt materials and surfaces like PVC, fabric, wire mesh and cleated are available to meet specific uses.



This special plastic belting has roller built into the belt. Allows easy diversion of product to other conveyors. Center device shown centers load.



Plastic belting used for delivery and assembly. Though more costly than standard belting, this new belting offers many unique advantages.



This belt conveyor features plastic belting.



Typical PVC belt conveyors. This feature center drives so fixed ends are possible.

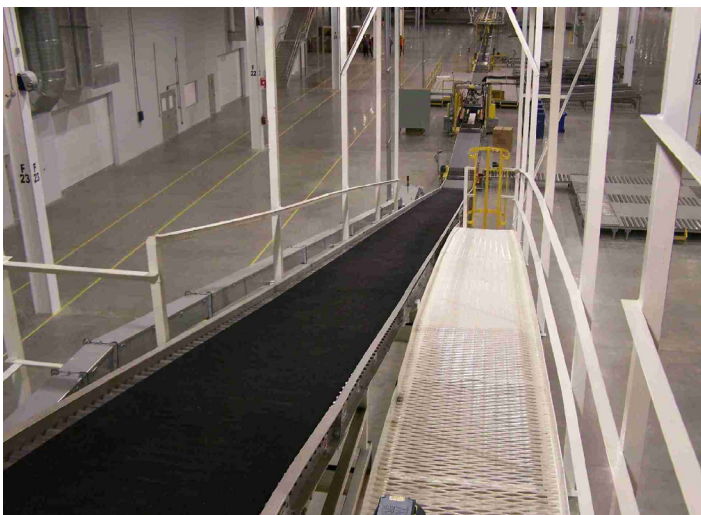

Belt Conveyors are used extensively for moving product to different elevations. This moves appliances from assembly to shipping.



Foundry troughing conveyor for feeding furnaces. Has built in weigh scales for material input.

WEBB-STILES designs and builds a wide variety of chain conveyors. Multi strand chain conveyors are used in all types of manufacturing, assembly and material handling. The most common chain conveyors built are Chain, Slat, Roller Flight and Fixture. All Chain Conveyor types are custom engineered to the job.



CHAIN CONVEYOR

CHAIN CONVEYOR

Chain conveyors are capable of handling light or very heavy loads. Special fixtures can also be engineered and built into the chain to handle a wide variety of loads. Simple or complex controls can be incorporated for batch processing.

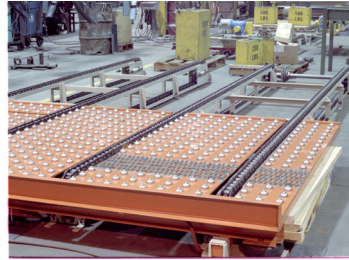

SLAT CONVEYOR

SLAT CONVEYOR

Slat Conveyors form a flat level surface and can convey a wide variety of objects. Slat conveyors can also be engineered to handle very heavy loads of 10,000 lbs and more. These conveyors can be microprocessor or computer controlled for accurate stop / start operations, etc. WEBB-STILES can build to your prints or we can do a complete turn-key operation from concept to installation.

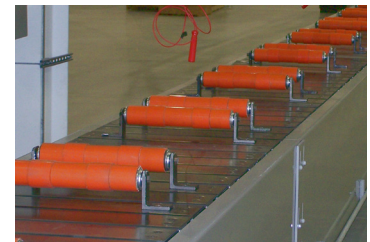

**HEAVY DUTY ACCUMULATING
CHAIN CONVEYOR**

ROLLER FLIGHT CONVEYOR

Roller Flight Conveyors are a powered dual strand chain conveyor with free running rollers mounted in a high position. This combination makes for a powered conveyor line that allows for simple accumulation to be made anywhere on the line by means of simple stops, with a minimum amount of back pressure force.

Roller Flight Conveyors can be designed to handle light or extremely heavy loads that are suitable for a roller bed conveyor.



WEBB STILES LIFTS AND VERTICAL CONVEYORS

WEBB-STILES engineers, builds, and installs all types of lifts and vertical conveyors for material handling and manufacturing. Pneumatic, electric and hydraulic disciplines can all be utilized to meet the specifications. Lifts can be effected by screw jacks, hydraulic and pneumatic air cylinders, scissors jacks, chain, cable and other methods.

All WEBB-STILES lifts and vertical conveyors are custom engineered and built for the job application.



WEBB-STILES continuous heavy duty lifts are a must where production and high cycle times are called for.



WEBB-STILES continuous Speedlifts from 100 to over 3000 pound load capabilities are a must where production and high cycle times are called for.



Reciprocating lift set up in our shop for testing. Intermediate sections will be installed at job site for final height of lift.



Power & Free "Lowerator" for truck cab system from paint to assembly.

SOME UNIQUE CONVEYORS WE'VE DONE

WEBB-STILES is not afraid to do what hasn't been done before, to solve our customer's really tough handling and conveying problems. If you can't find somebody to tackle one of your tough problems, let us have a shot at it. Let our 54 years of experience solve your problems.



WALKING BEAMS

WEBB-STILES engineers and builds walking beams and beam accumulators for handling all types of loads. Beam accumulators as shown handle many different sizes as found on frames, etc. Special Indexers are also great for handling all types of loads for assembly or process through ovens, etc.

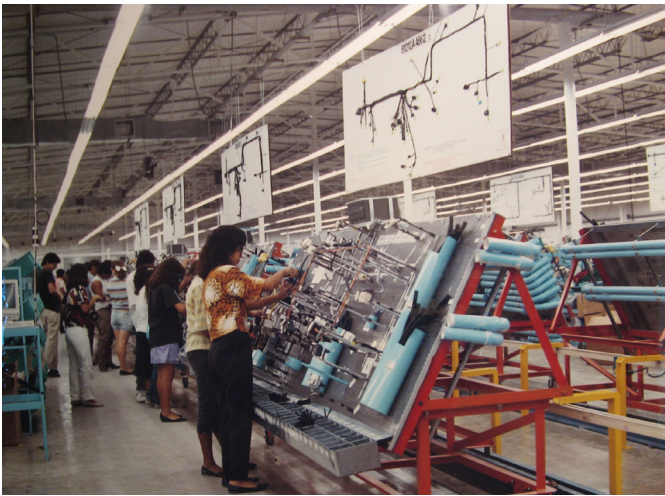

ASSEMBLY LINES

WEBB-STILES has built and installed assembly lines for all industries, automotive, truck and construction, appliance and other unique assembly operations.

If you are looking for an assembly line, call your Webb-Stiles Sales Engineer to be on your bid list.



STORAGE AND RETRIEVAL SYSTEMS

For that unique product you need to store, retrieve or balance your production, WEBB-STILES has a solution with our heavy duty storage and retrieval systems. Custom engineered and built to fit your special needs. Many proven installations for unique needs. Capable of handling loads from 250 to 5000 pounds or more.





SUPER HEAVY DUTY SYSTEMS

WEBB-STILES has the engineering and fabricating know-how to build the heaviest of conveying systems. From handling the heaviest steel plates made to bull dozers, rely on WEBB-STILES for handling your big needs.



PROCESS LINES

WEBB-STILES can handle your process line handling needs whether it be paint, ovens, heat treat or the many other processes needing conveyance. Monorails, Power & Free, spindle, chain or the many other solutions we have for keeping your processes moving.



AIR CARGO

We work with all the major next day shippers and Defense in the air cargo and sortation business. Whether it's a major hub or local sort station; our many years in the business assures you of reliable rugged equipment.





All WEBB-STILES Control Systems are engineered by our staff of electrical engineers for total accuracy and reliability. This in-house engineering assures you of getting and maintaining your system through years of service and makes any upgrades that may be required in the future easily accomplished with the need for outside assistance. WEBB-STILES not only engineers the controls but we do all our programming and testing of our controls in-house. On many of our contracts we send our electrical engineers to start-up, de-bug and train our customers personnel on the controls and operation of the conveyor system. WEBB-STILES is capable of engineering the most sophisticated of controls in use today.

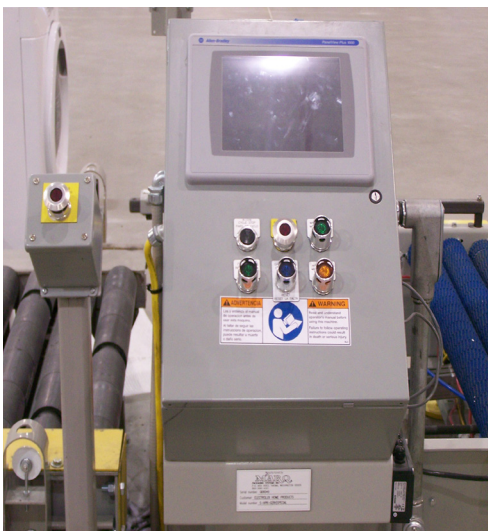



DESIGN ENGINEERING

WEBB-STILES has a staff of knowledgeable mechanical and electrical engineers at both our plants that design and engineer your equipment to meet your exact needs without compromise. With total in-house engineering capabilities, WEBB-STILES offers absolute design control and central decision making; an important consideration when dealing with any system regardless of size.

FABRICATION

WEBB-STILES has two fully equipped plants enabling us to do all fabrication work in-house. Our highly skilled craftsmen build your equipment using methods and techniques refined by years of experience. We only use the highest quality parts and materials and our craftsmen are dedicated to delivering a product that is defect free and will provide years of dependable service.

INSTALLATION

Our field installations are handled by one of our Senior Field Superintendents. It is their responsibility to manage a crew of skilled craftsmen familiar to the trades to install your equipment. By shipping many of our components pre-assembled and pre-tested; we can reduce installation and labor costs. Our engineers also direct the installation and commissioning of the more sophisticated equipment such as electrical control systems.



WEBB-STILES COMPANY

The Webb-Stiles Company was founded in 1956 and specializes in custom designed material handling systems. The Company has grown and expanded over the years culminating with our main plant and corporate headquarters in Valley City, Ohio (just south of Cleveland) and our Southern Division in Gadsden, Alabama.

We maintain engineering staffs at both locations with many years of conveyor experience in the mechanical, structural and electrical disciplines. The two plants consist of over 300,000 square feet enabling Webb-Stiles to handle all its fabrication work in-house.

The volume and diversity of conveyors manufactured by Webb-Stiles continually expands. It now includes many standard items, as well as a wide variety of specialty units.

Webb-Stiles also manufactures and installs all types of overhead trolley and Power & Free conveyors along with a complete range of floor conveyors of all types. We maintain sales engineers in our Valley City and Gadsden plants with several remote sales offices. For more information or assistance, please feel free to contact any of our offices.



Webb-Stiles Company - Valley City, OH



Webb-Stiles of Alabama - Gadsden, AL

Visit our website www.webb-stiles.com to learn more about our products and capabilities.

WEBB-STILES, A WHOLE WORLD OF CONVEYOR EQUIPMENT.



Accumulating Conveyors
Apron Conveyors
Ball Tables
Belt Driven Live Roller
Belt Conveyors
Bolsters
Carriers
Cart-Trac
Carrousel
Cat Drives
Chain Conveyors
Chain Driven Live Roller
Chain Transfers
Cleated Belt
Converging Sections
Diverter

Downenders
Drag Chain Conveyors
Fixture Conveyors
Floor Conveyors
Gate Sections
Gravity Conveyors
Guided Pallet
Herringbone Roller
Hydraulic Conveyors
Inclined Reciprocating
Live Roller
Lineshaft
Live Storage
Merge Sections
Overhead Trolley
Pallet Collectors

Pallet Conveyors
Pallet Dispensers
Pickup & Delivery Sta.
Platform Conveyors
Portable Conveyors
Power & Free
Power Curves
Pusher Bar
Pusher Chain
Reciprocating Beam
Retarding Conveyors
Roller Conveyors
Roller Flight
Roller Slat
Roller Chain
Shuttle Conveyors

Slat Conveyors
Sortation Conveyors
Speed-Lift Conveyors
Spindle Conveyors
Tow Line Conveyors
Takeups
Transfer Cars
Turnover Devices
Troughed Roller
Turntables
Upenders
Vertical Continuous
Vertical Reciprocating
Walking Beam
Wire Mesh

***ENGINEERING**

***MANUFACTURING**

***INSTALLATION**



WEBB-STILES COMPANY

www.webb-stiles.com
webb-stiles@webb-stiles.com

Main Plant & Corporate Office
675 Liverpool Drive
PO Box 464
Valley City, OH 44280
Ph: 330-225-7761
Fx: 330-225-5532

Webb-Stiles of Alabama - Southern Division
700 Industrial Parkway
PO Box 2608
Gadsden, AL 35903
Ph: 256-492-6642
Fx: 256-492-7300